



FULL SERVICE



OPERATOR SYSTEMS FOR GARAGE DOORS



OPERATOR SYSTEMS FOR SECTIONAL DOORS



OPERATOR SYSTEMS FOR SLIDING GATES



OPERATOR SYSTEMS FOR HINGED GATES



OPERATOR SYSTEMS FOR ROLLER SHUTTERS



PARK BARRIER SYSTEMS



ELECTRONIC CONTROL UNITS



PRODUCT SERVICE



ACCESSORIES

D.



Abb. D.1



Abb. D.2

D.

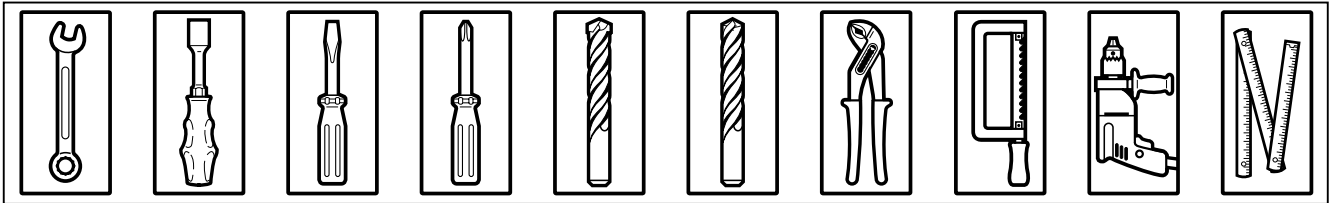
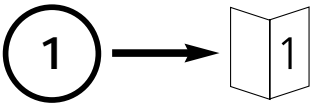

Abb. D.3

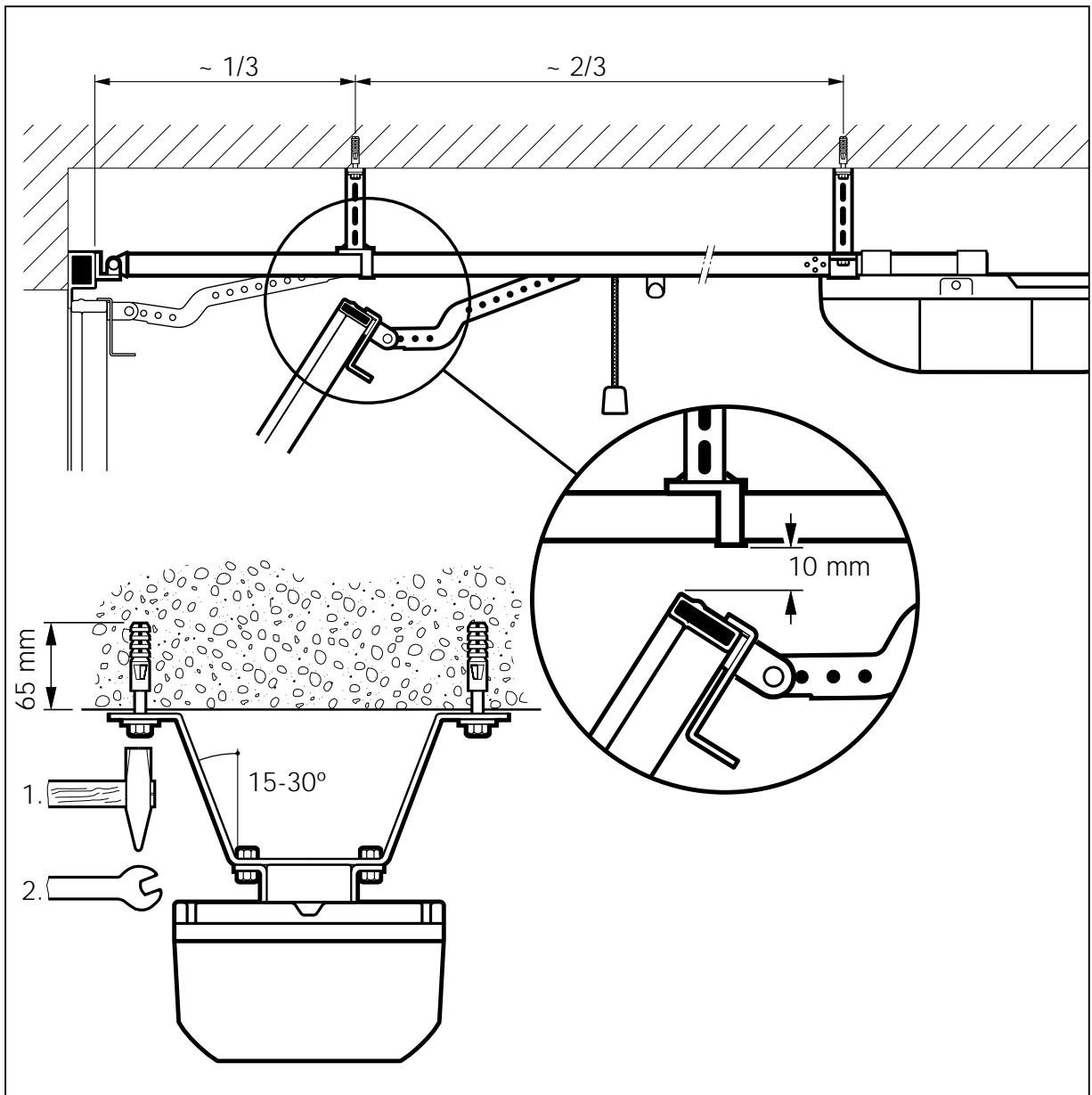

Abb. D.4

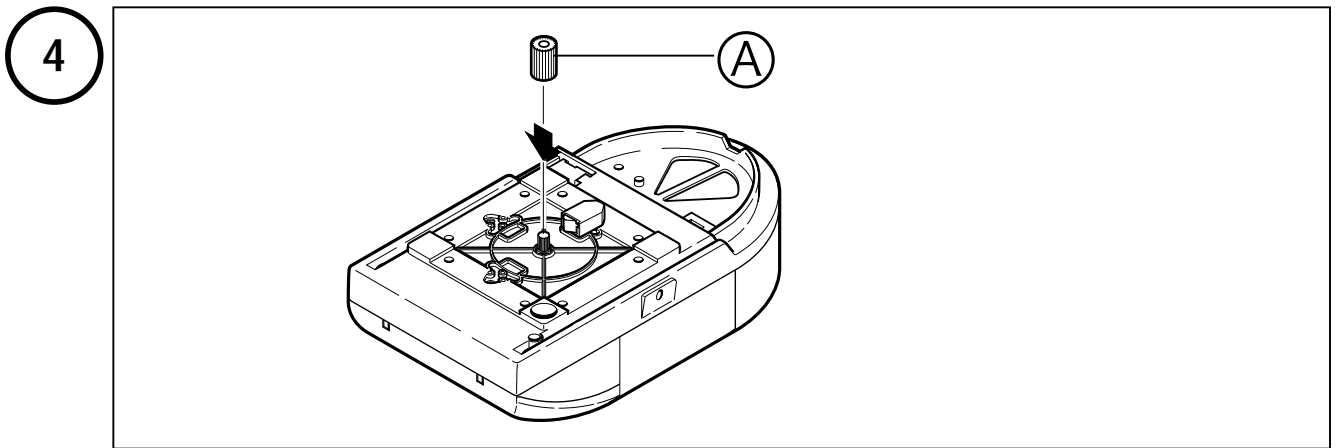

Abb. D.5

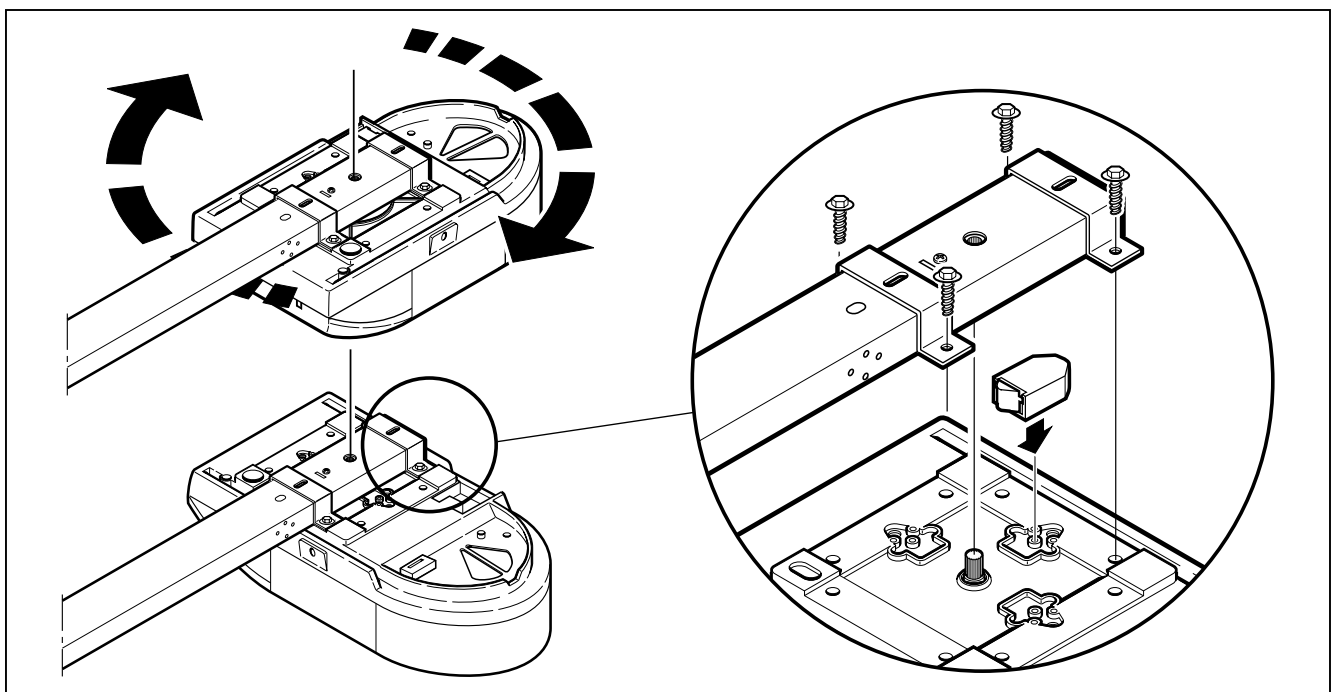

Abb. D.6

D.

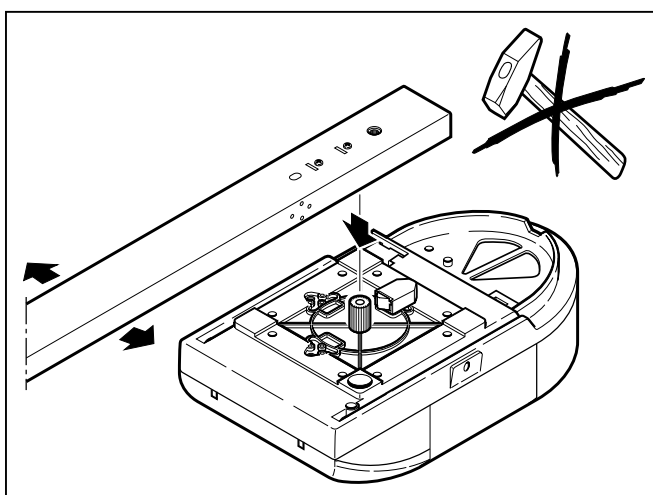

Abb. D.7:

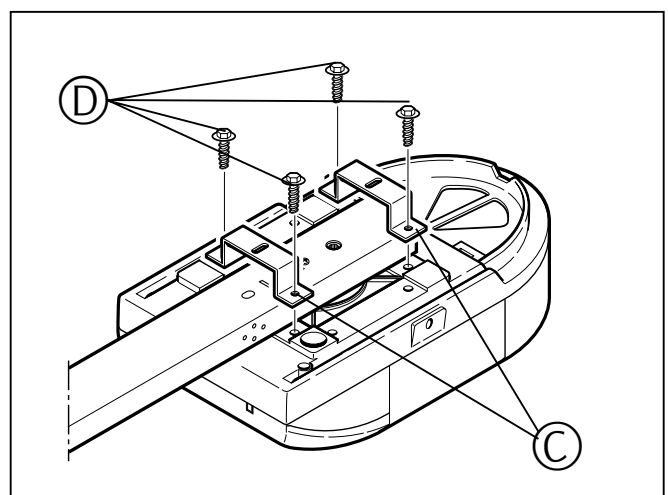

Abb. D.8:

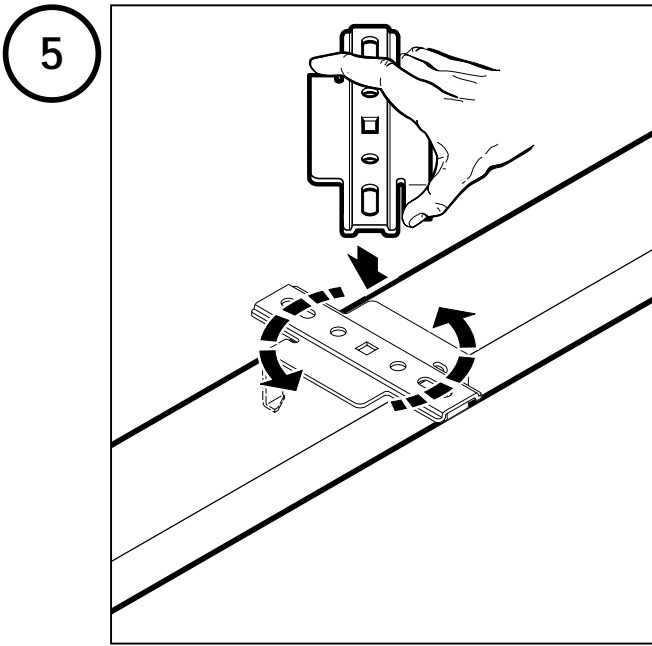

Abb. D.9:

D.

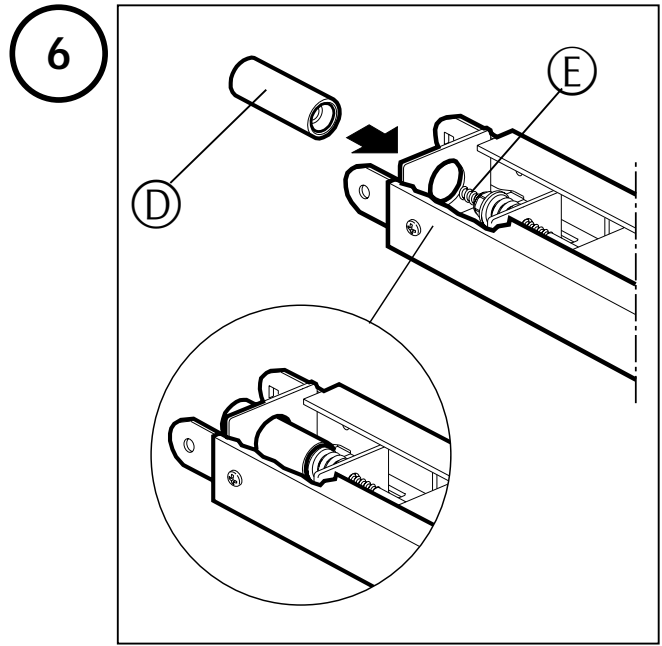
7

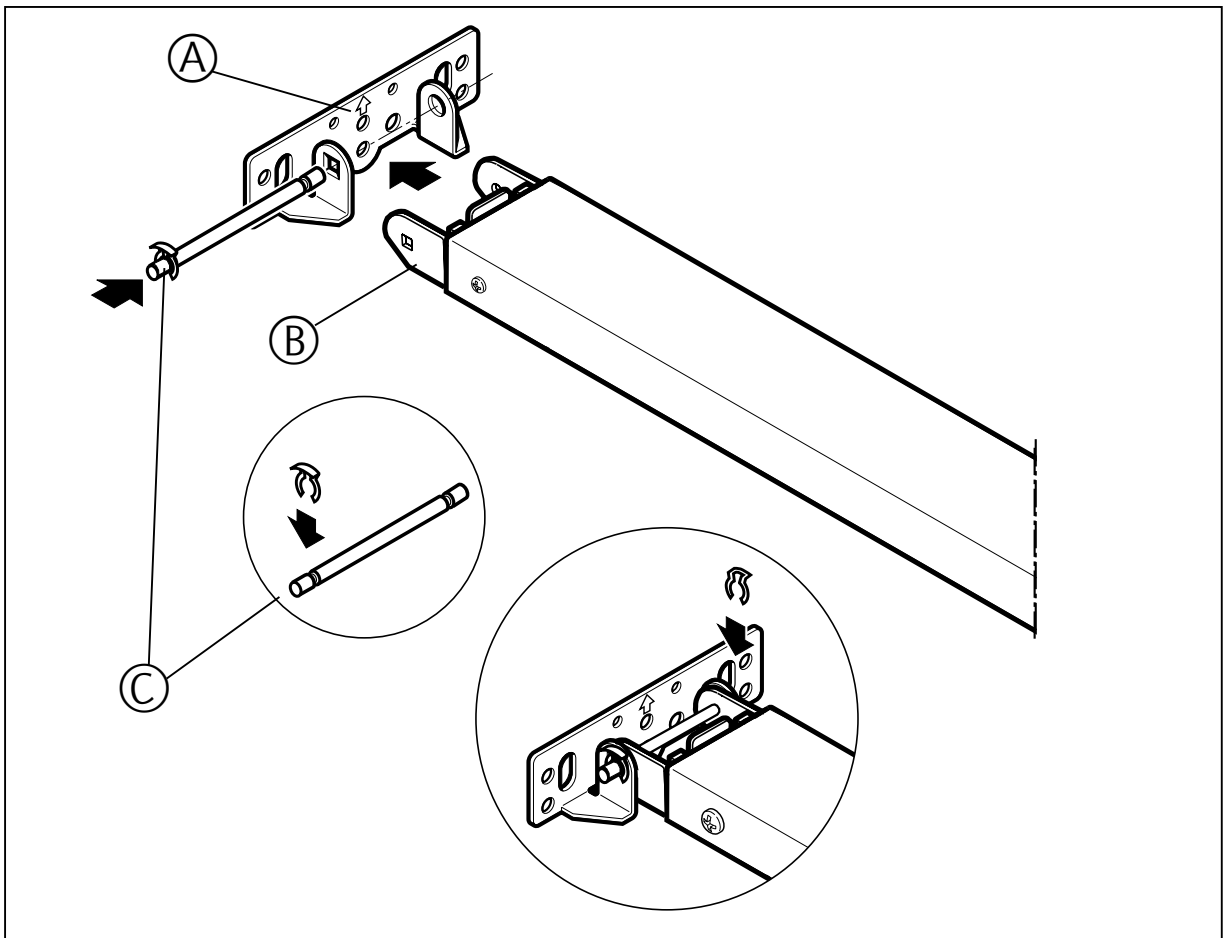

Abb. D.10



Abb. D.11

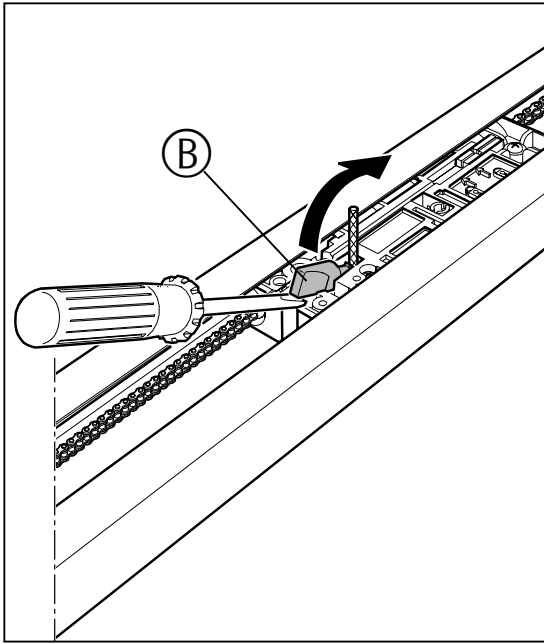

Abb. D.12

D.

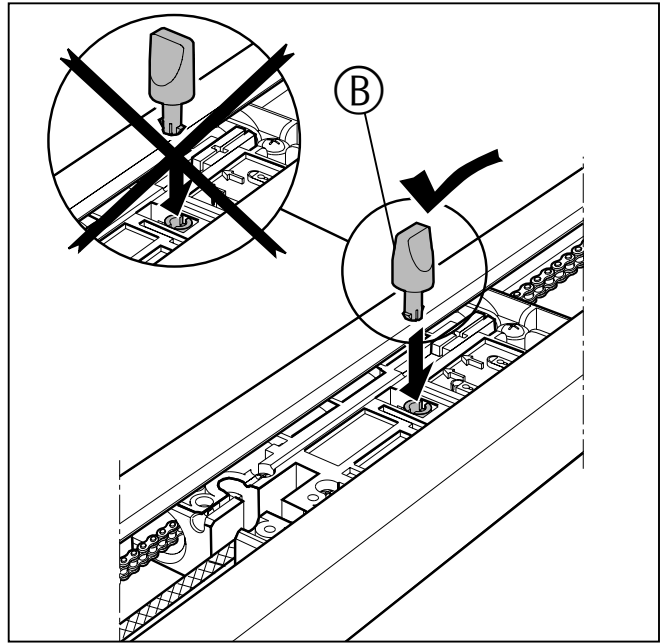
8

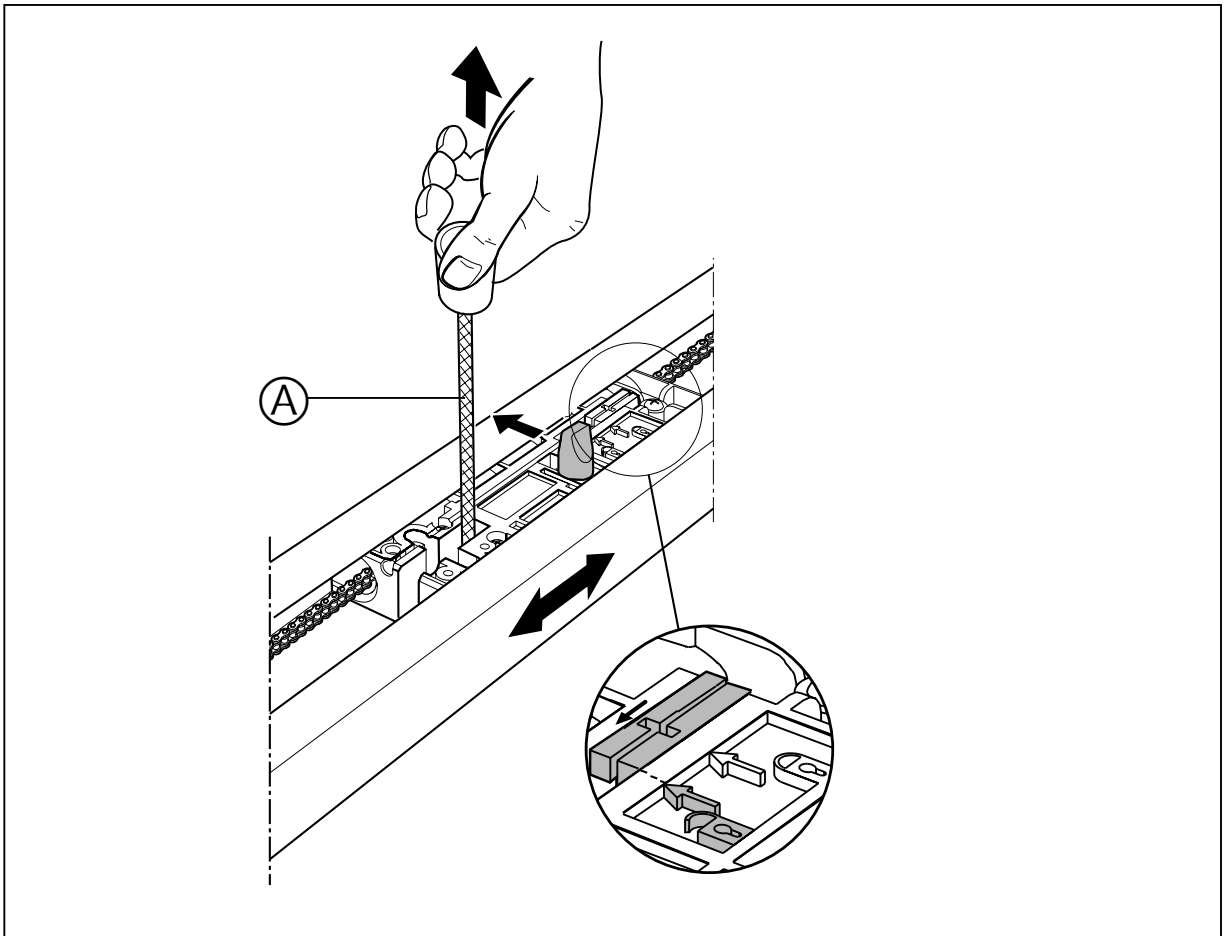

Abb. D.13

D.

9

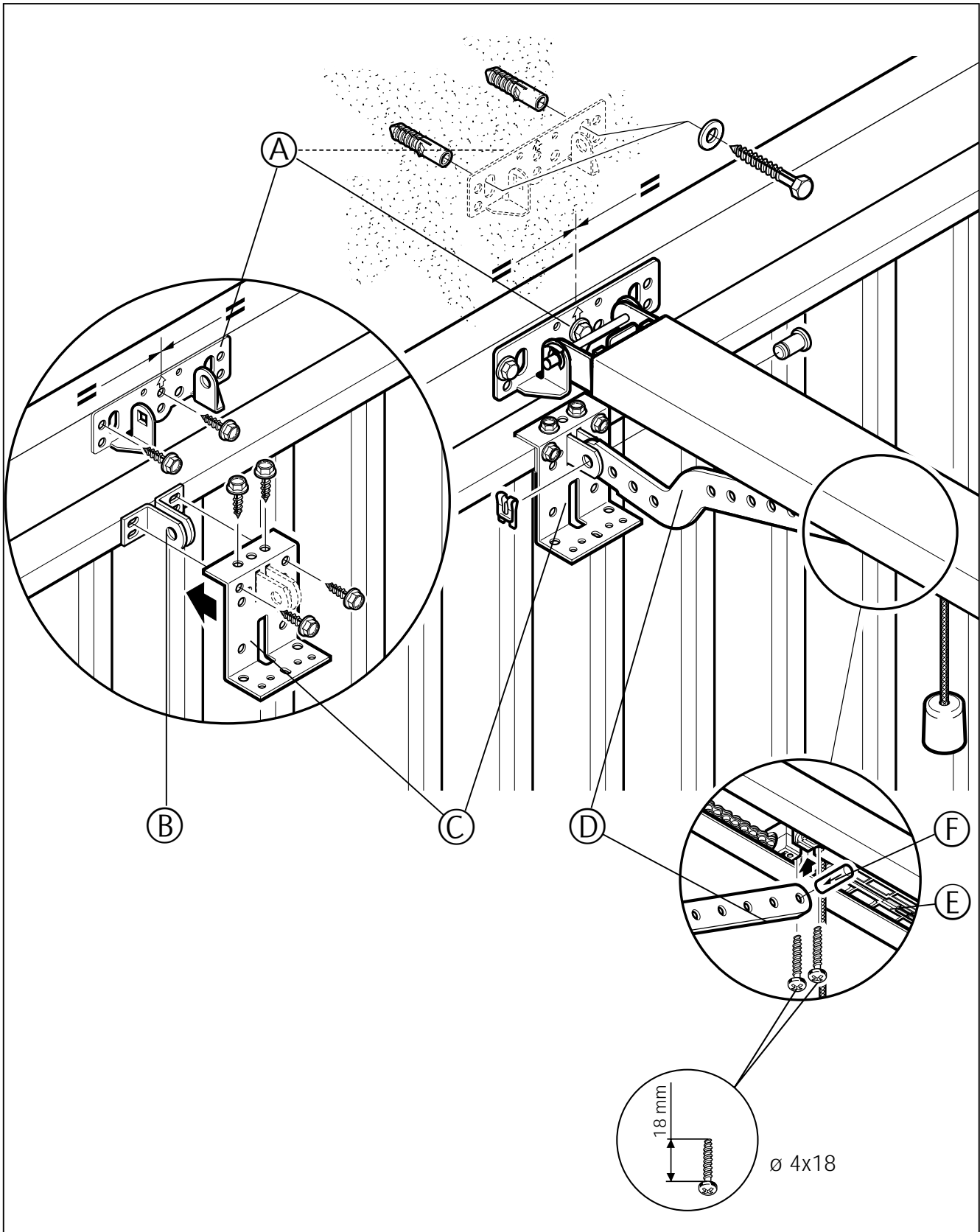

Abb. D.14

D.

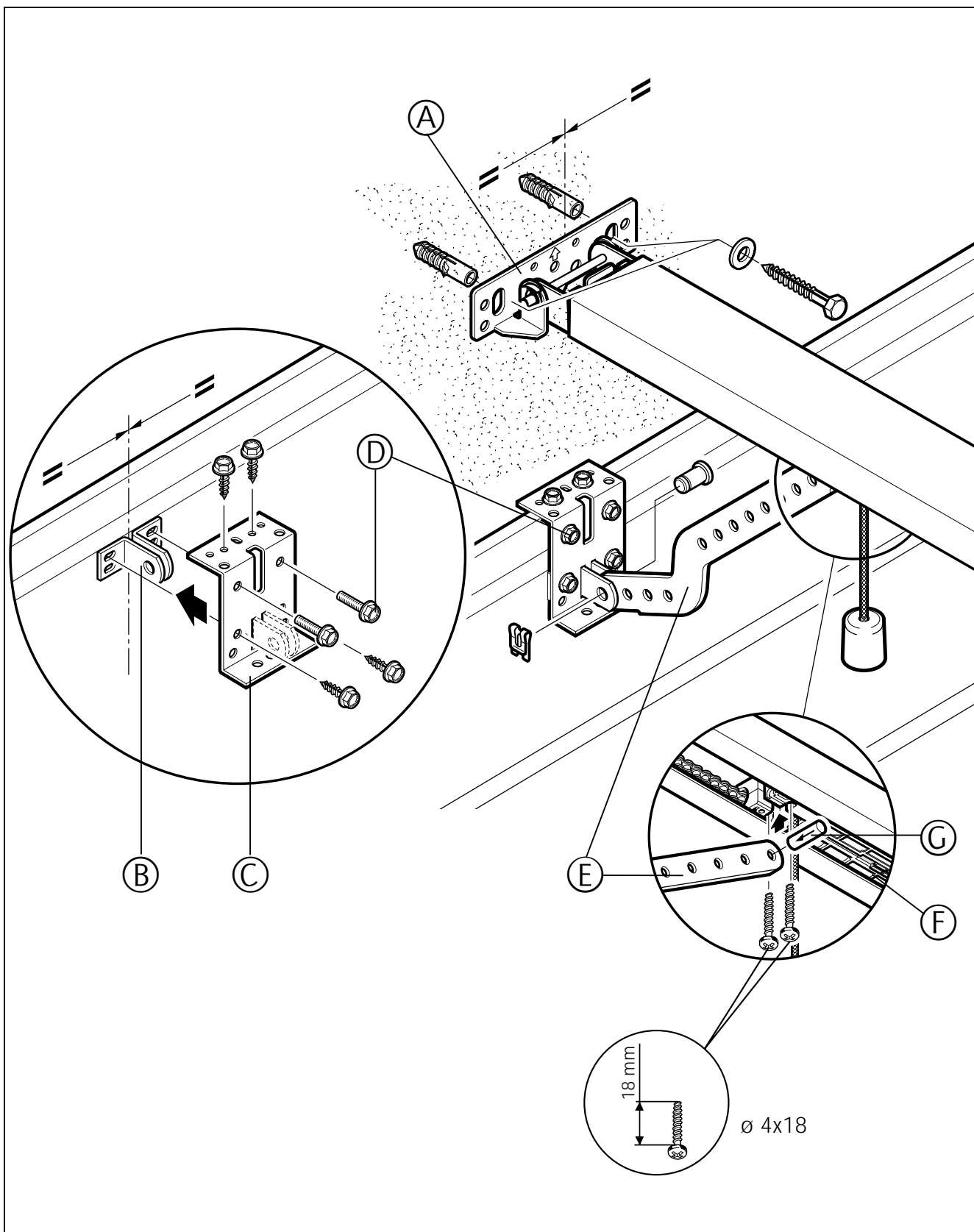

Abb. D.15

D.

10

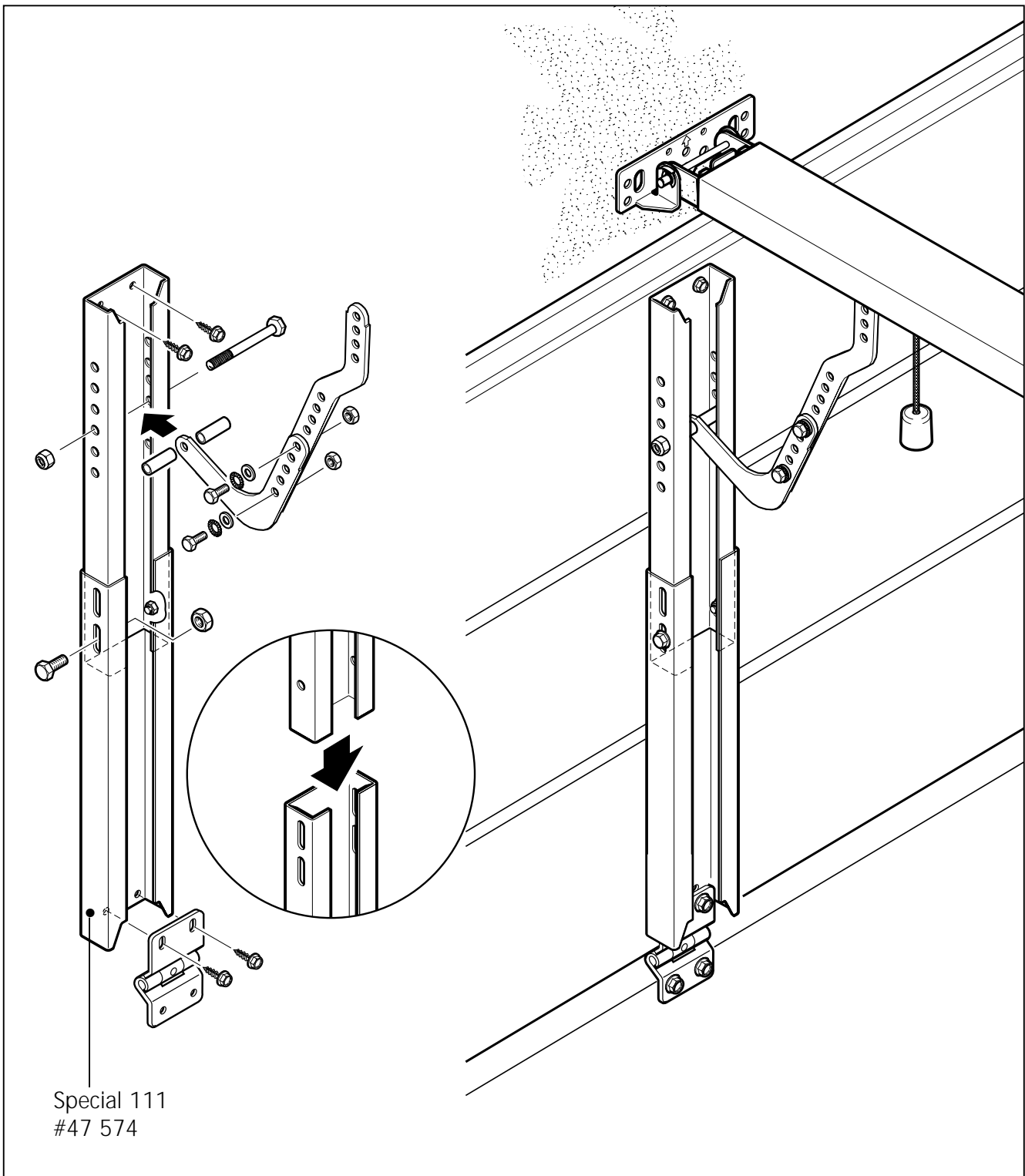

Abb. D.16



Abb. D.17

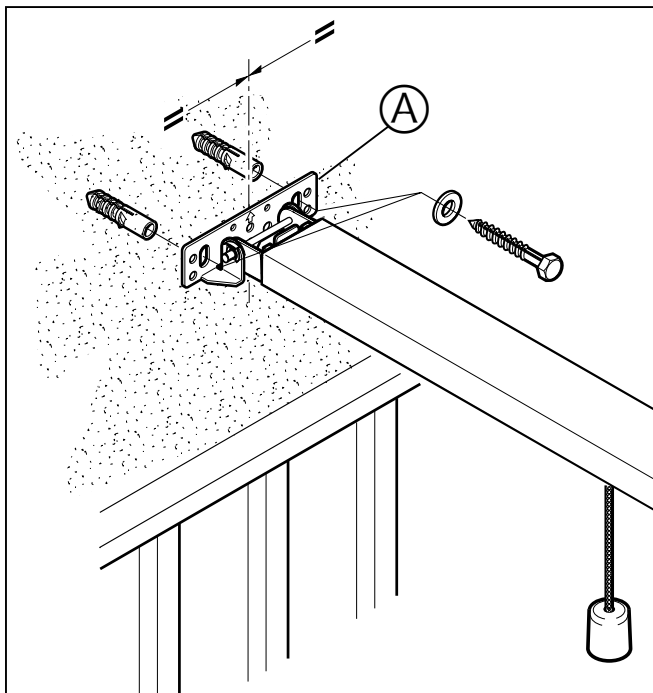

Abb. D.18

D.

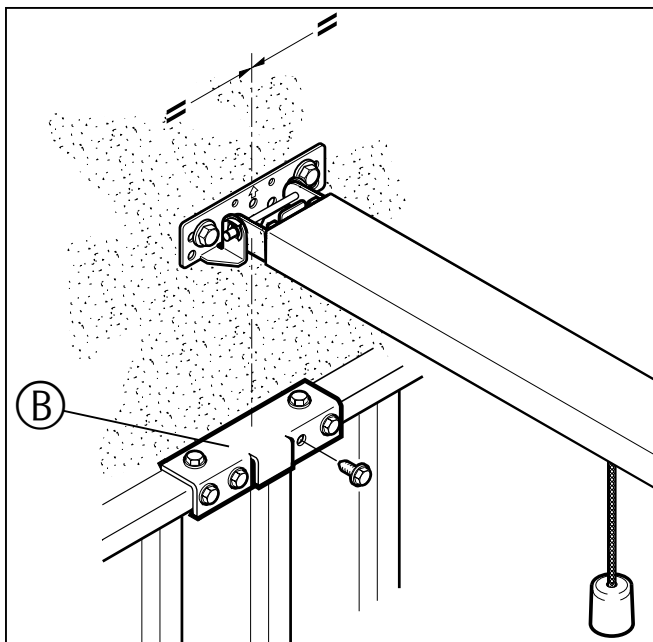

Abb. D.19

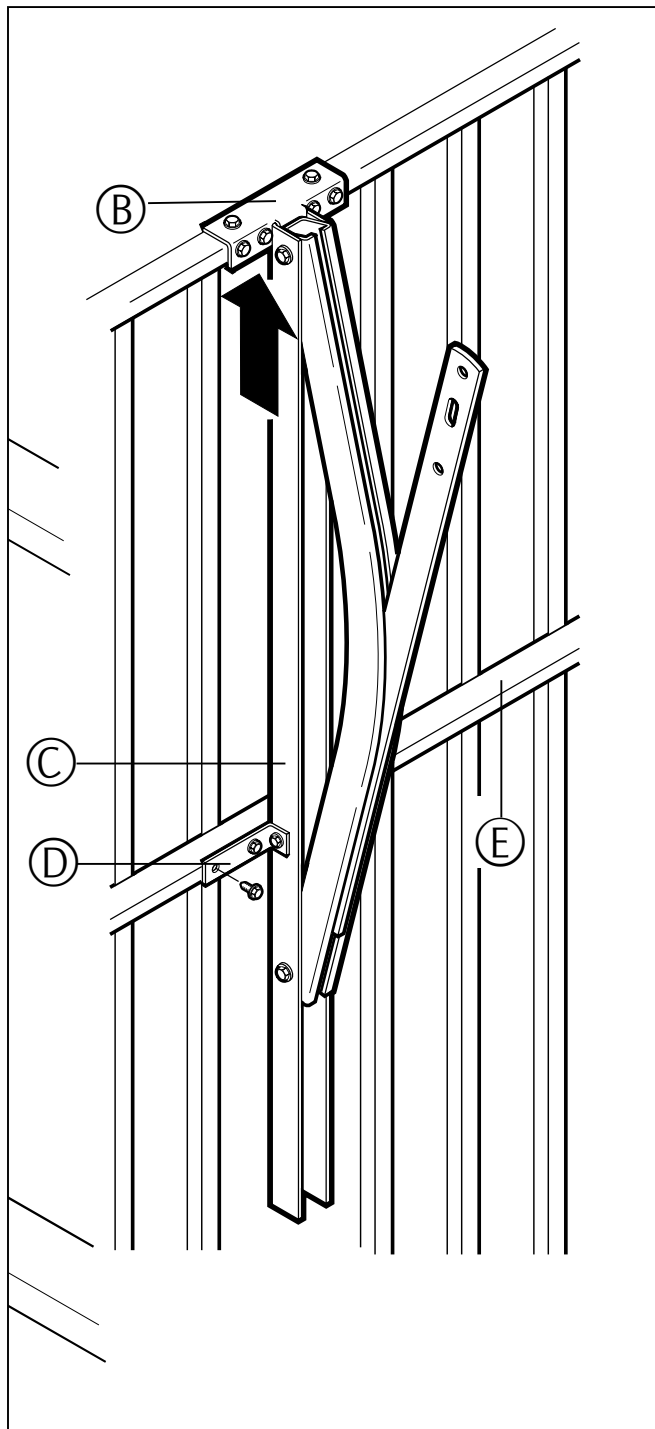
11

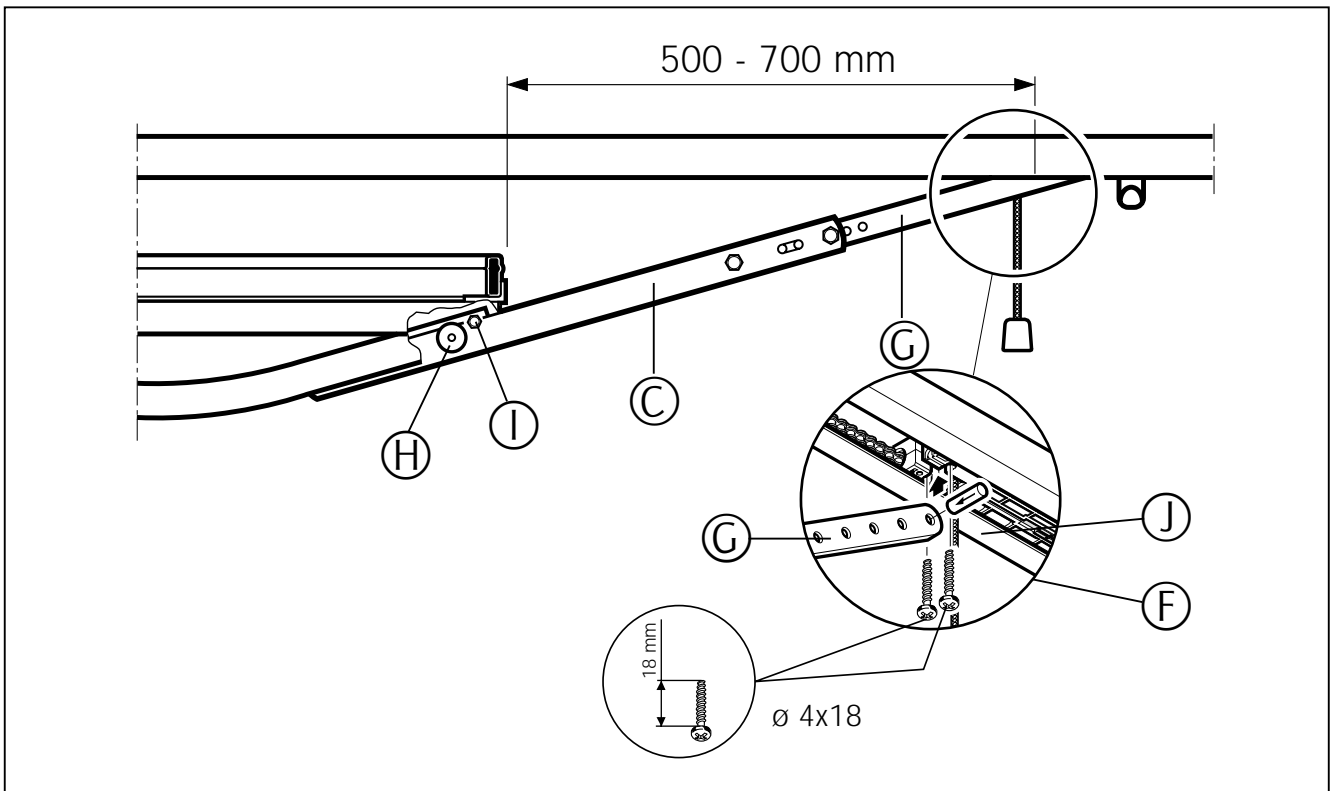

Abb. D.20

D.

12

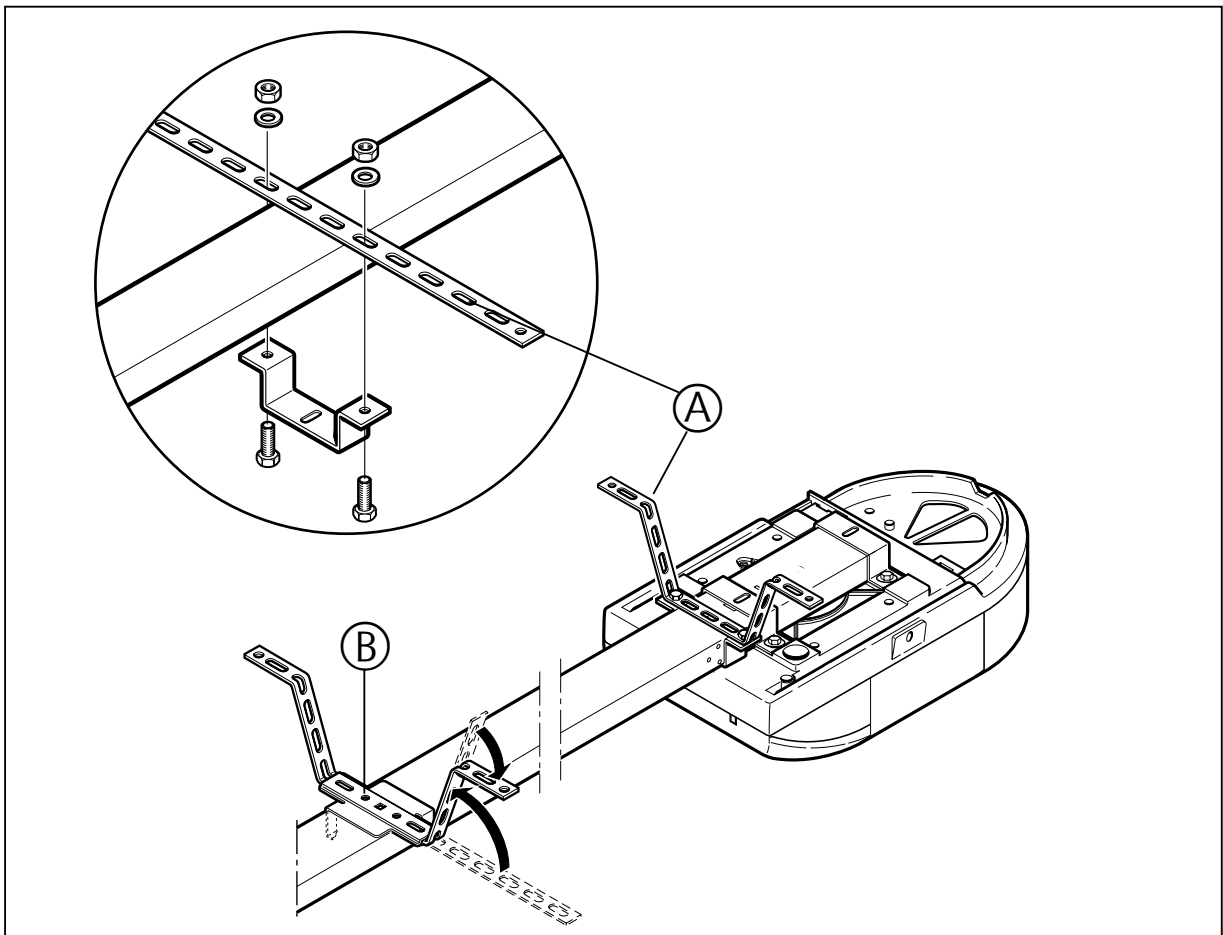

Abb. D.21

13



Abb. D.22

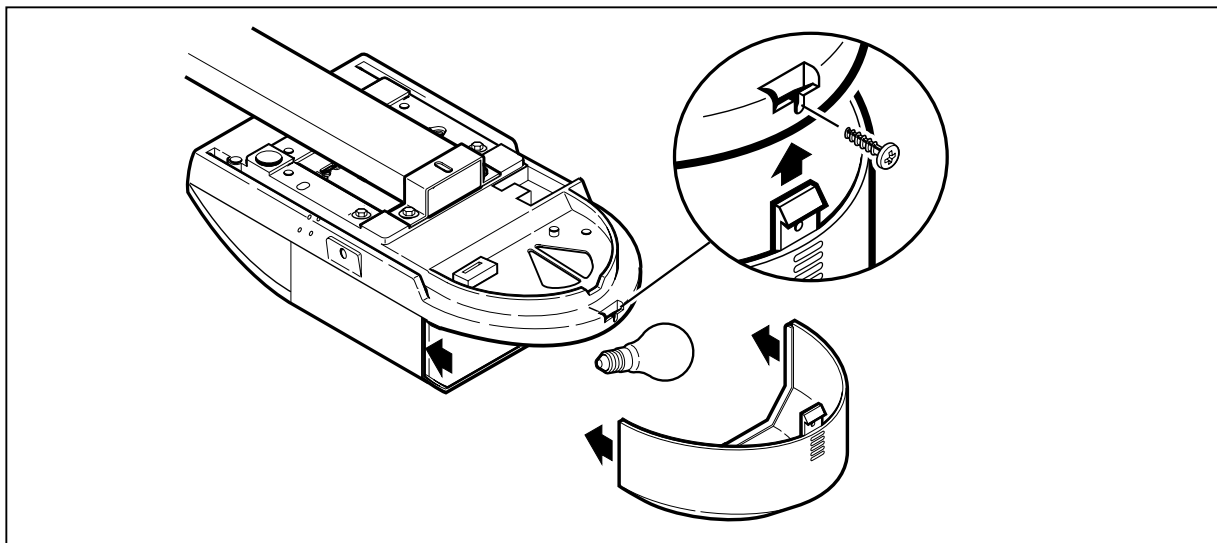

Abb. D.23

D.

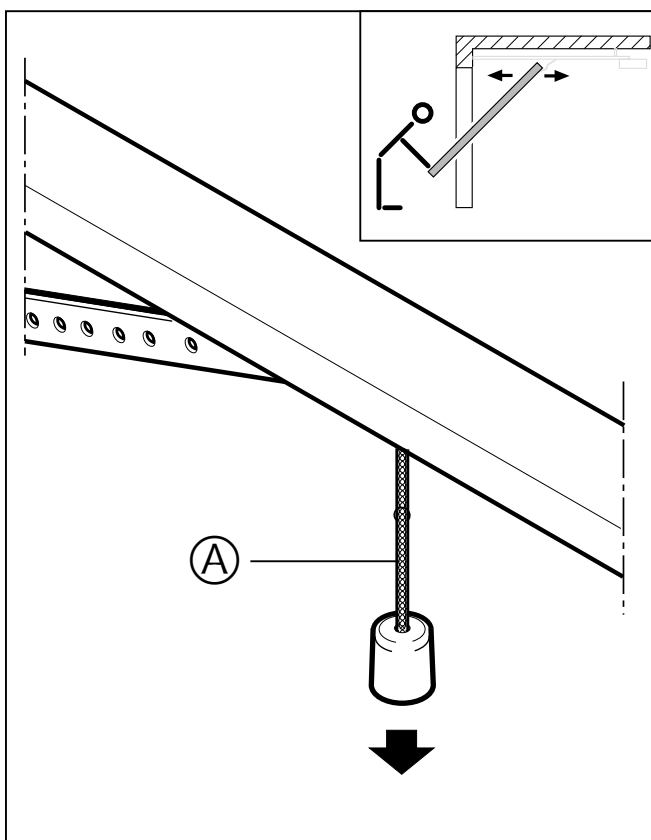

Abb. D.24

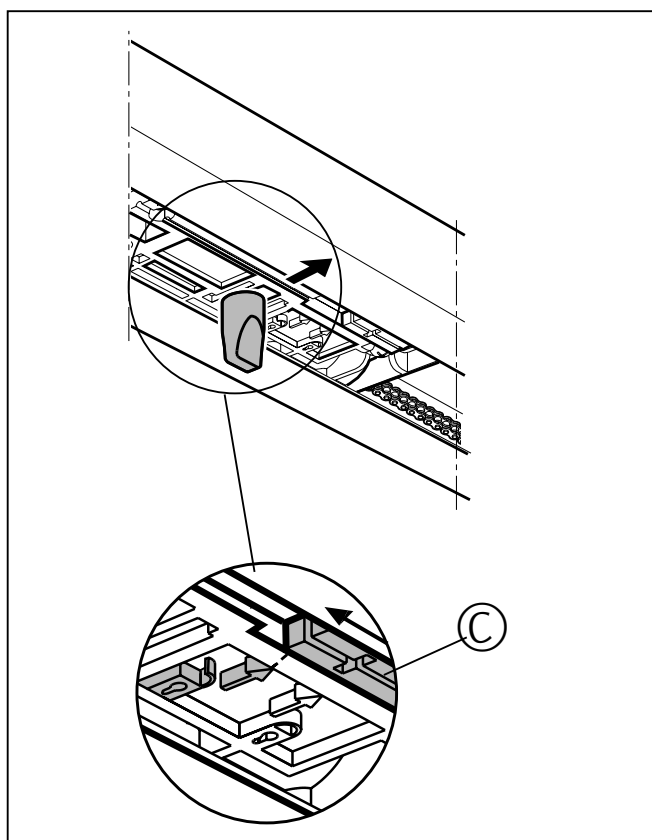

Abb. E.1

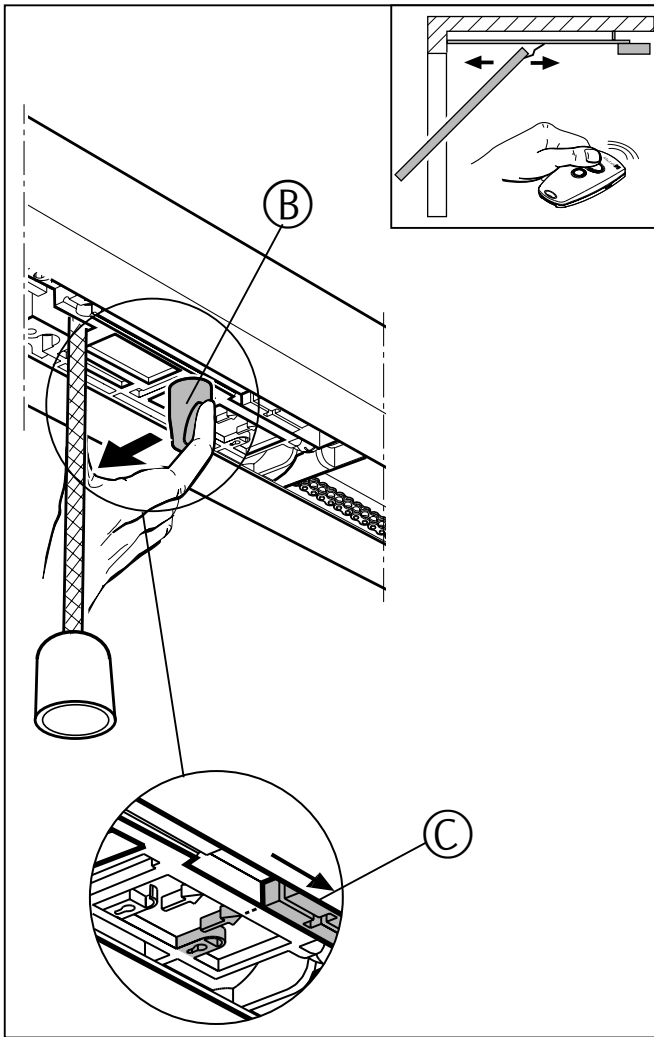

Abb. E.2

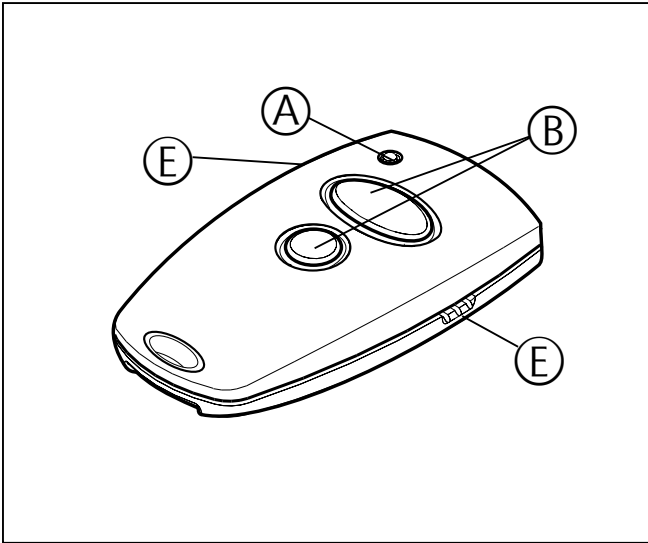

Abb. E.3

15

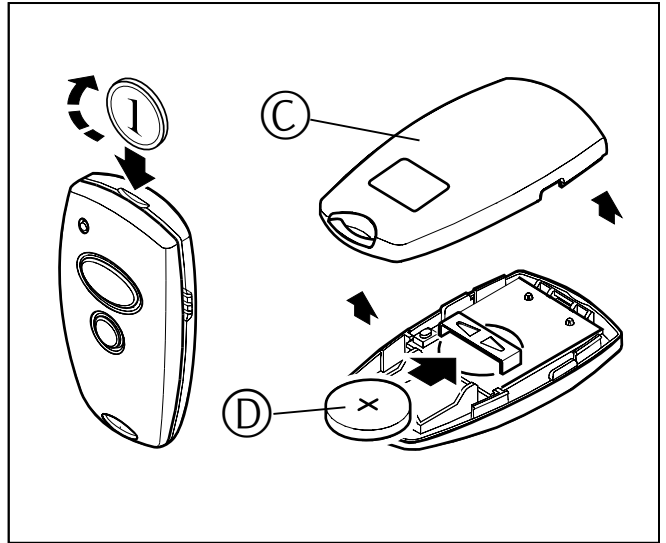

Abb. E.4

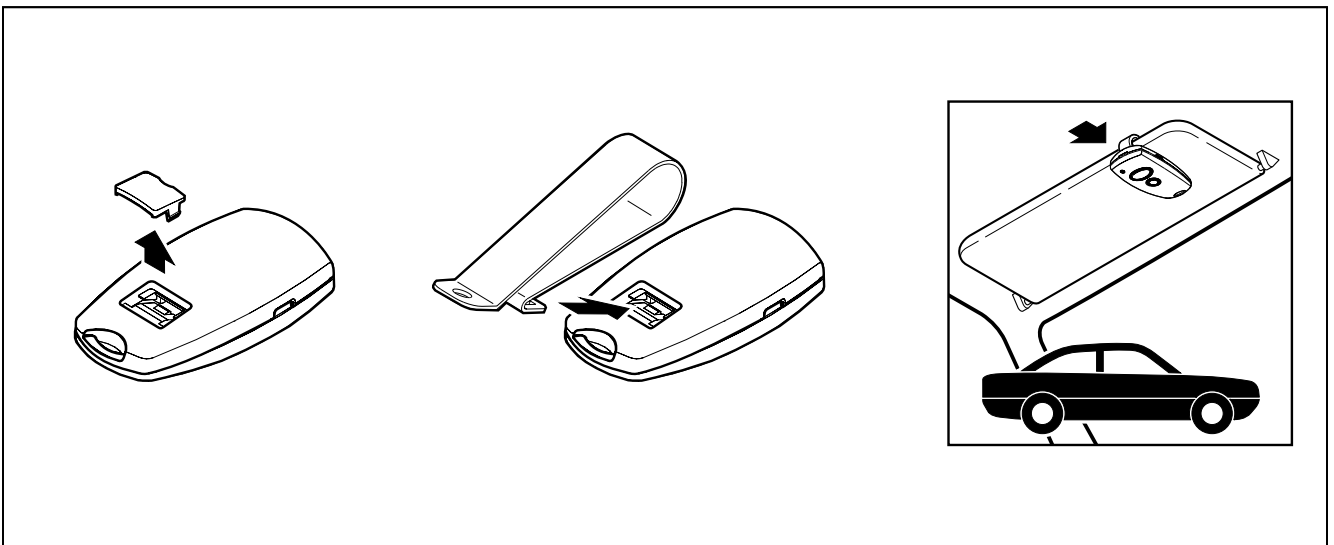

Abb. E.5

F.

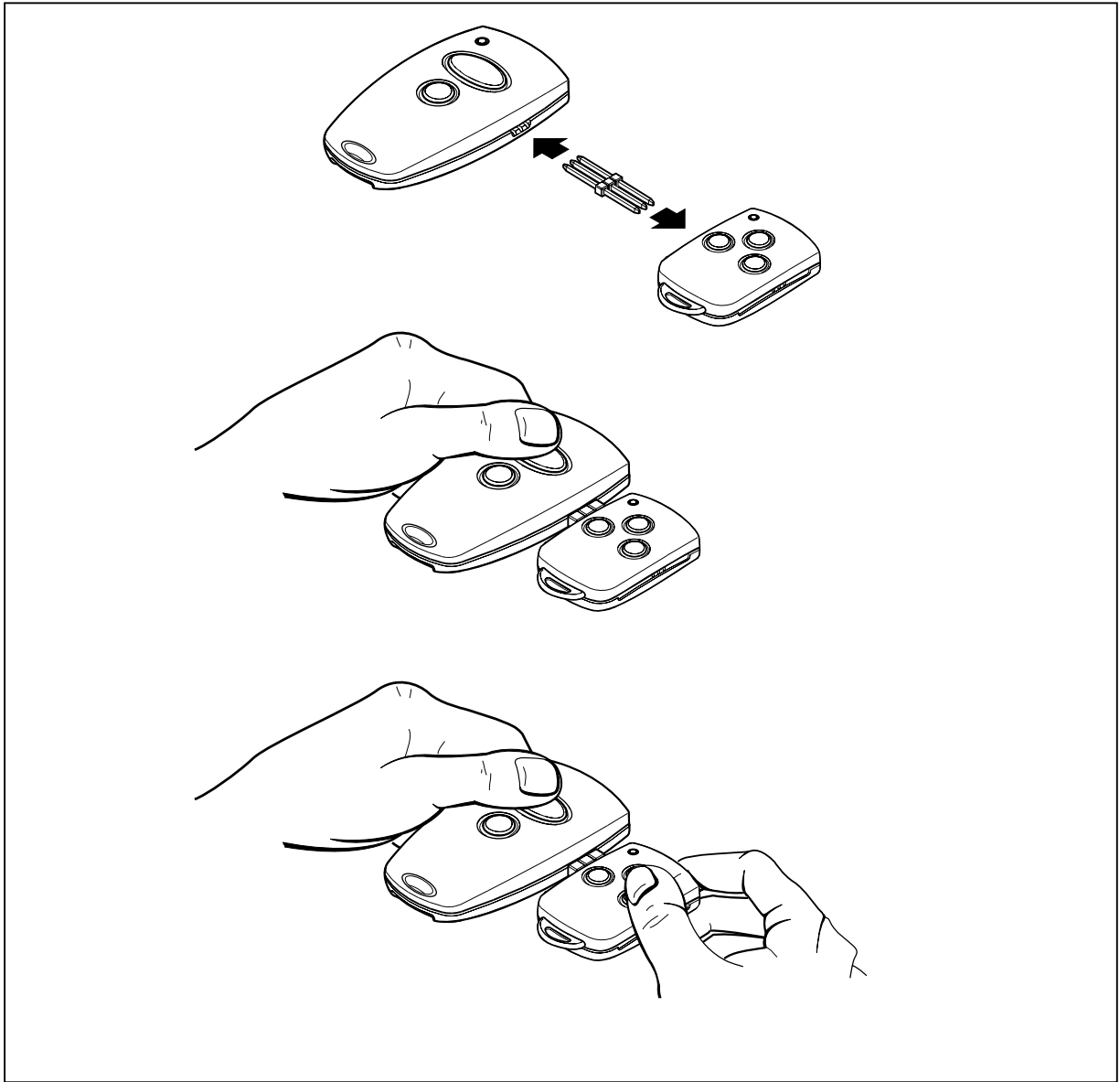
16

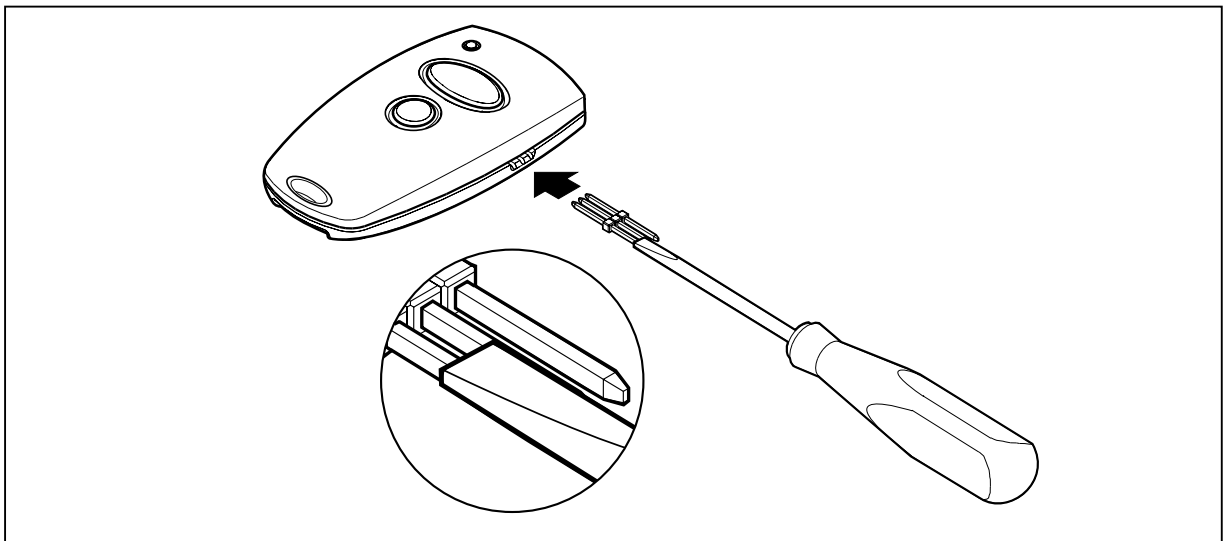

Abb. F.1

17



Abb. F.2

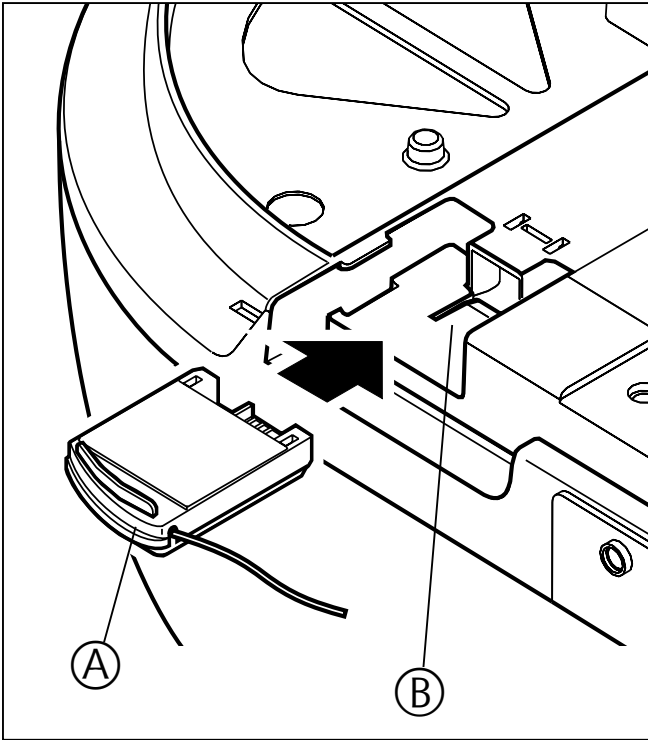

Abb. F.3

G.

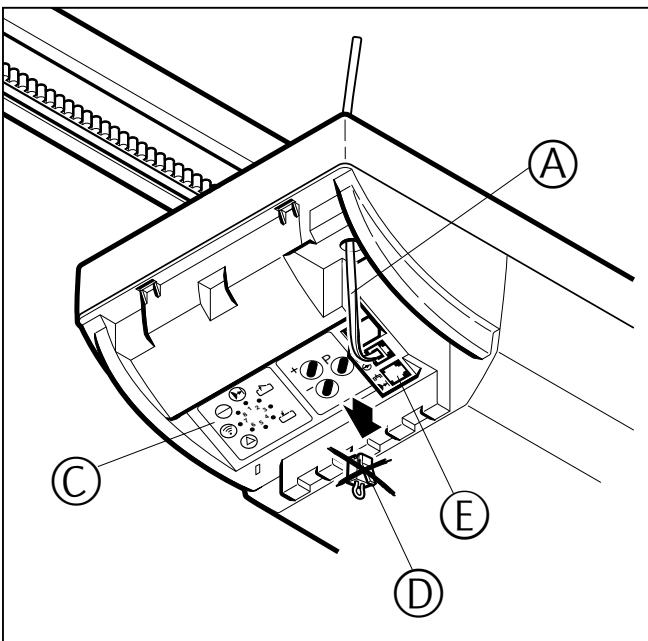

Abb. G.1

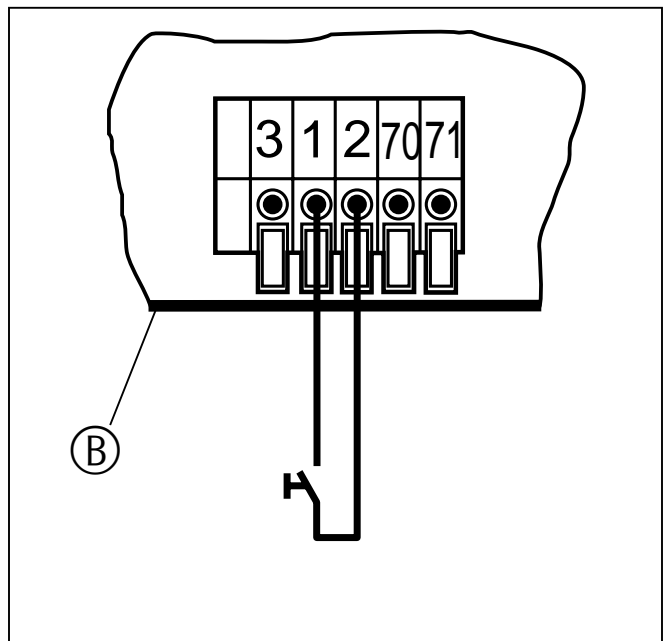

Abb. G.2

G.

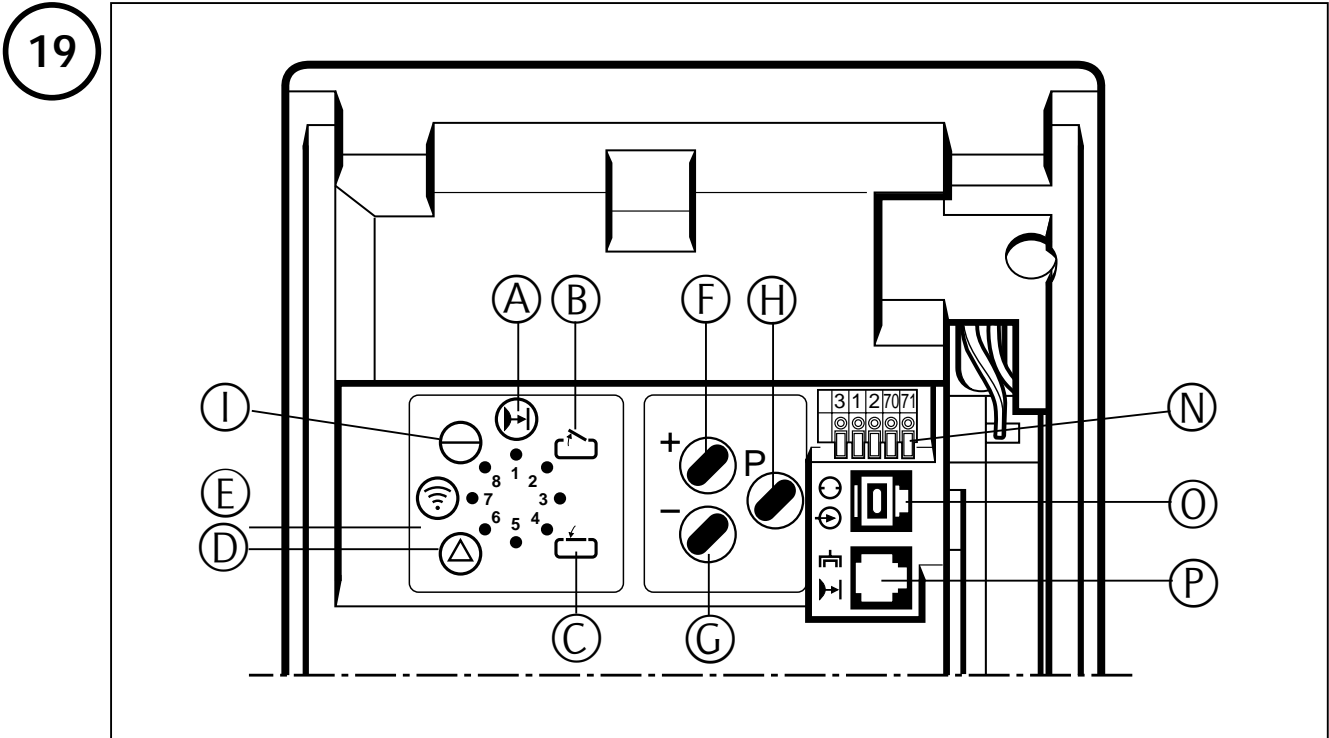
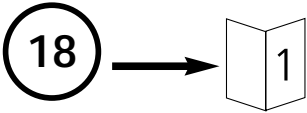

Abb. G.3

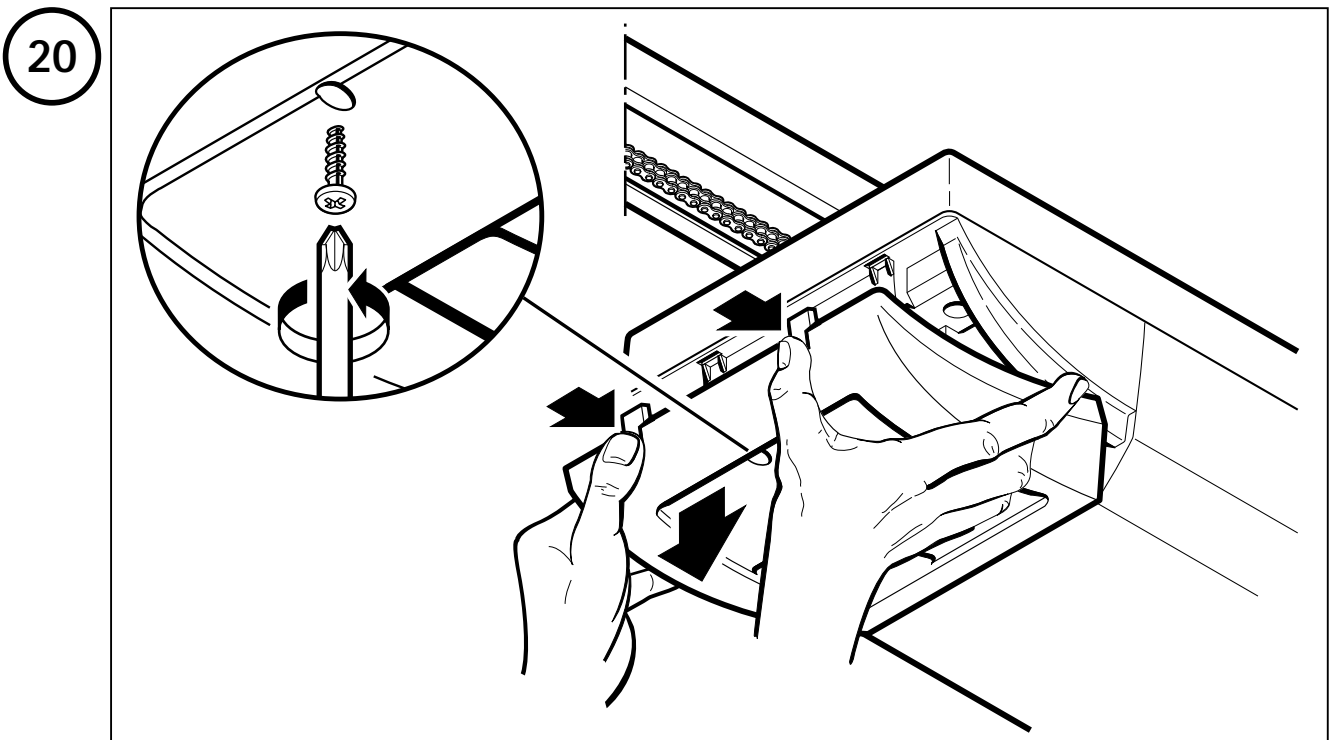
G.

27

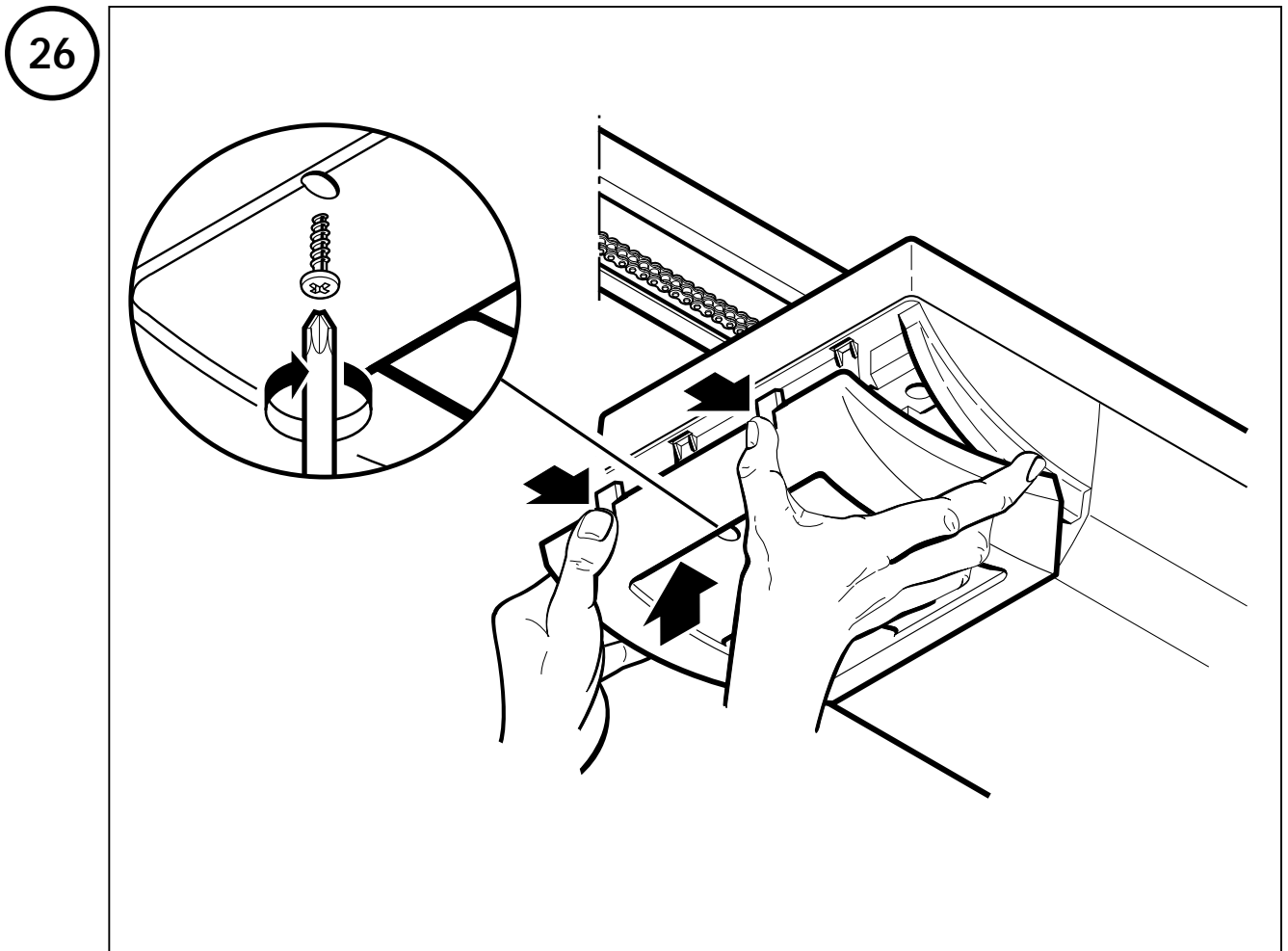
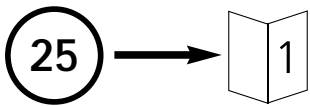
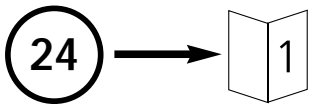
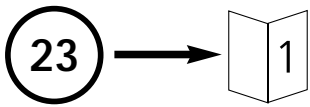
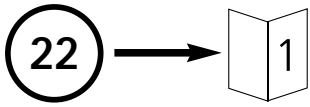
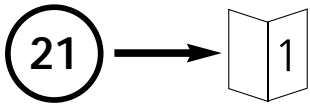

Abb. G.4



Abb. G.5

O.

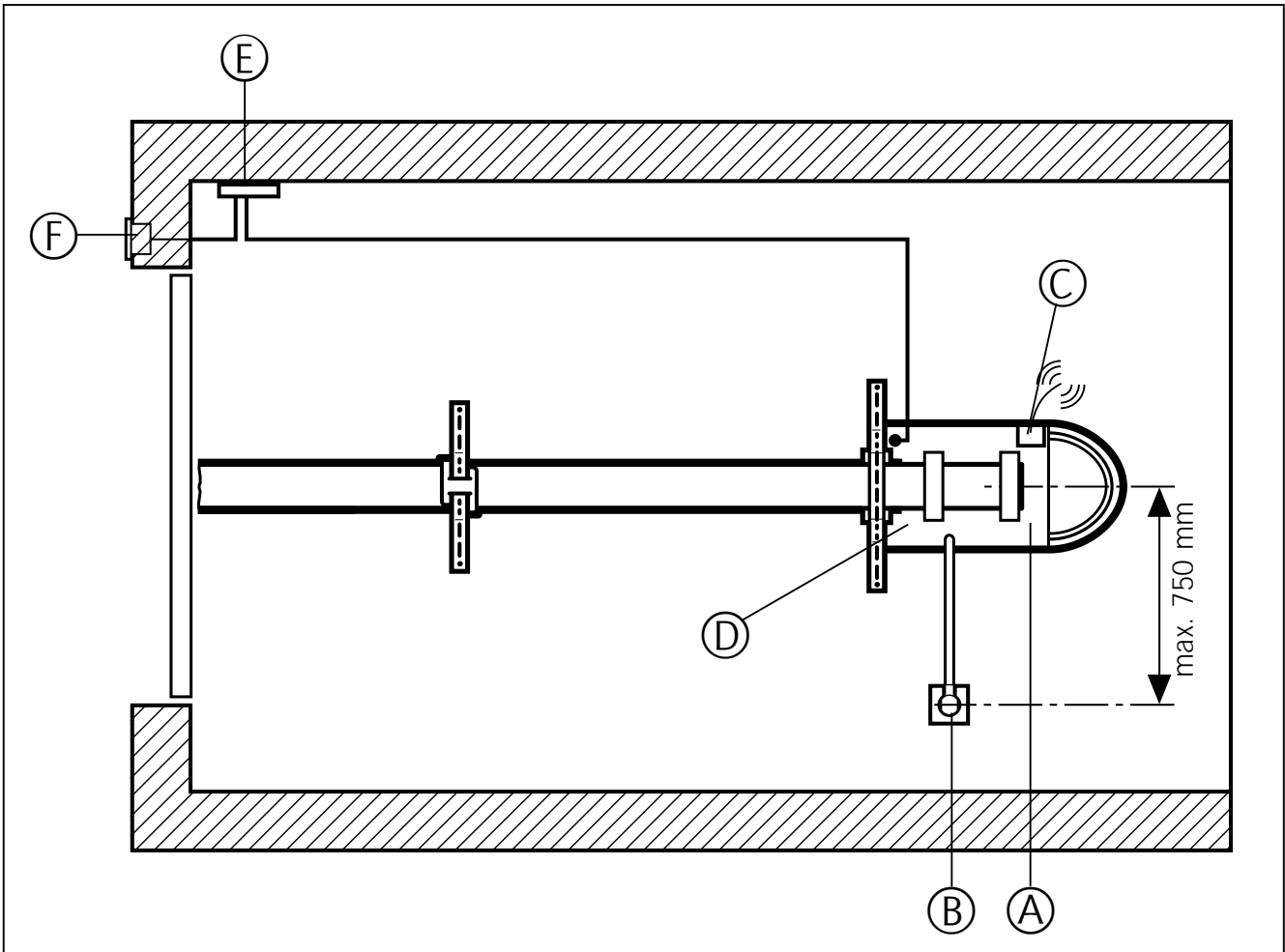

Abb. O.1

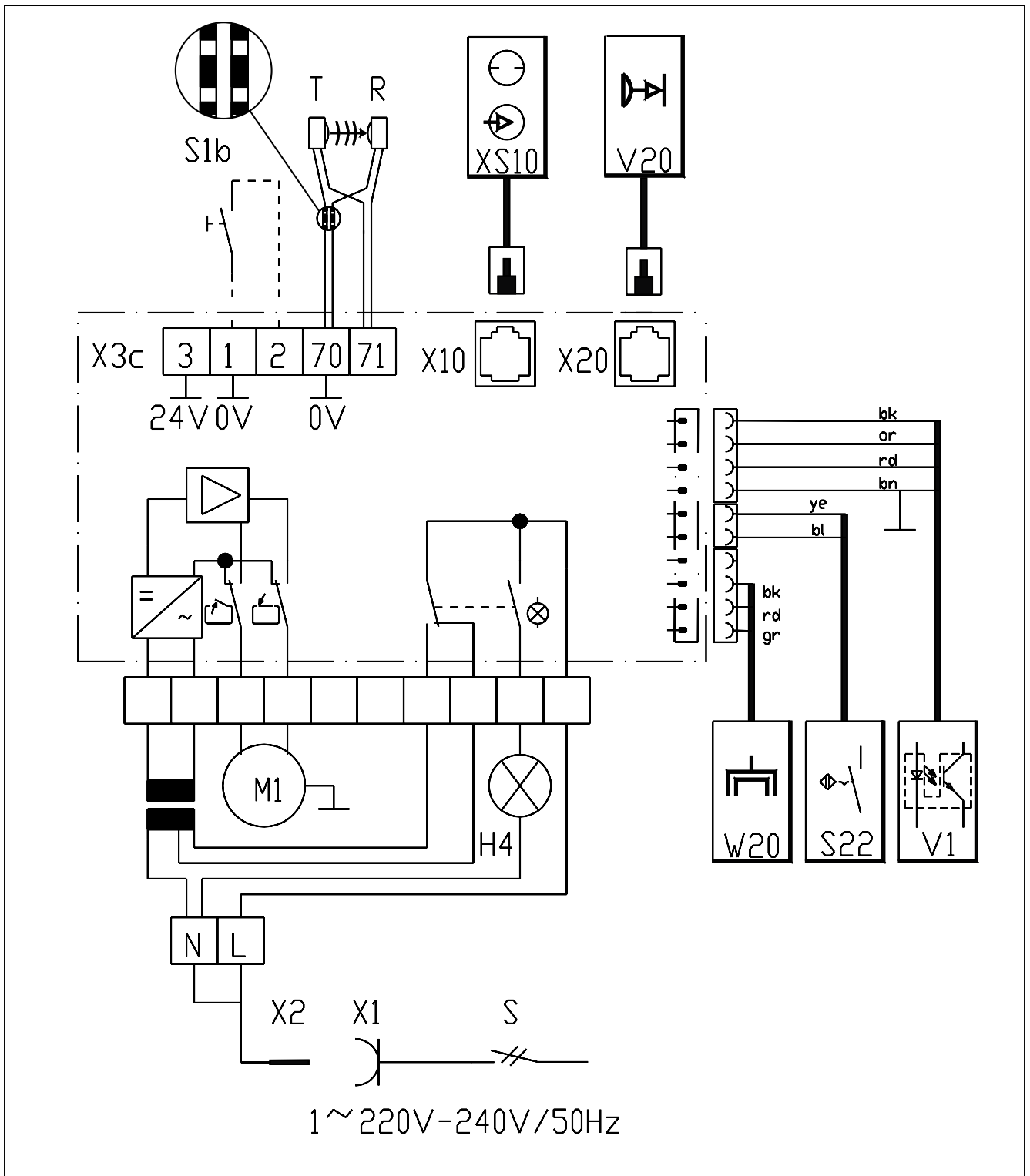
O.



Abb. O.2

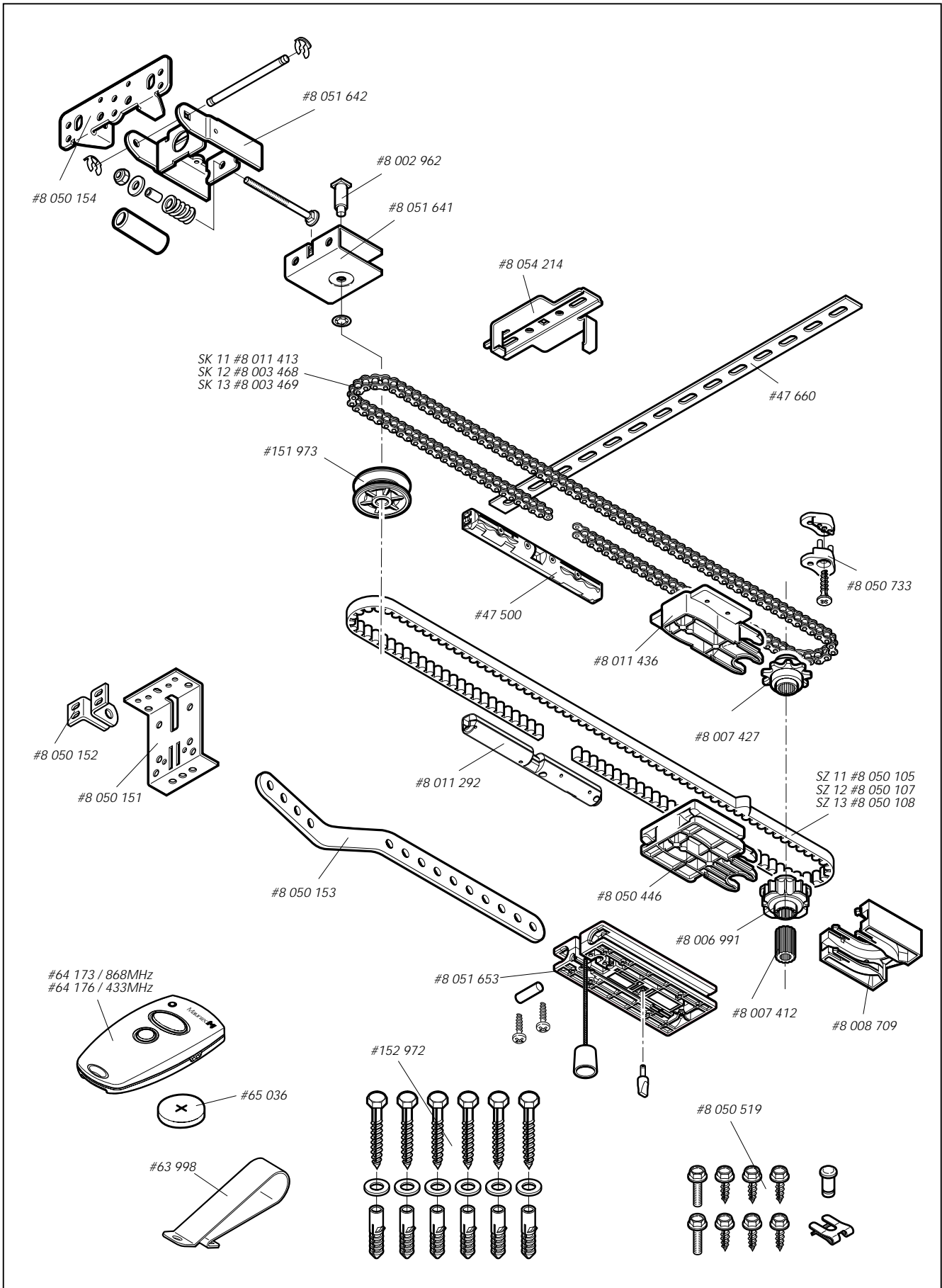

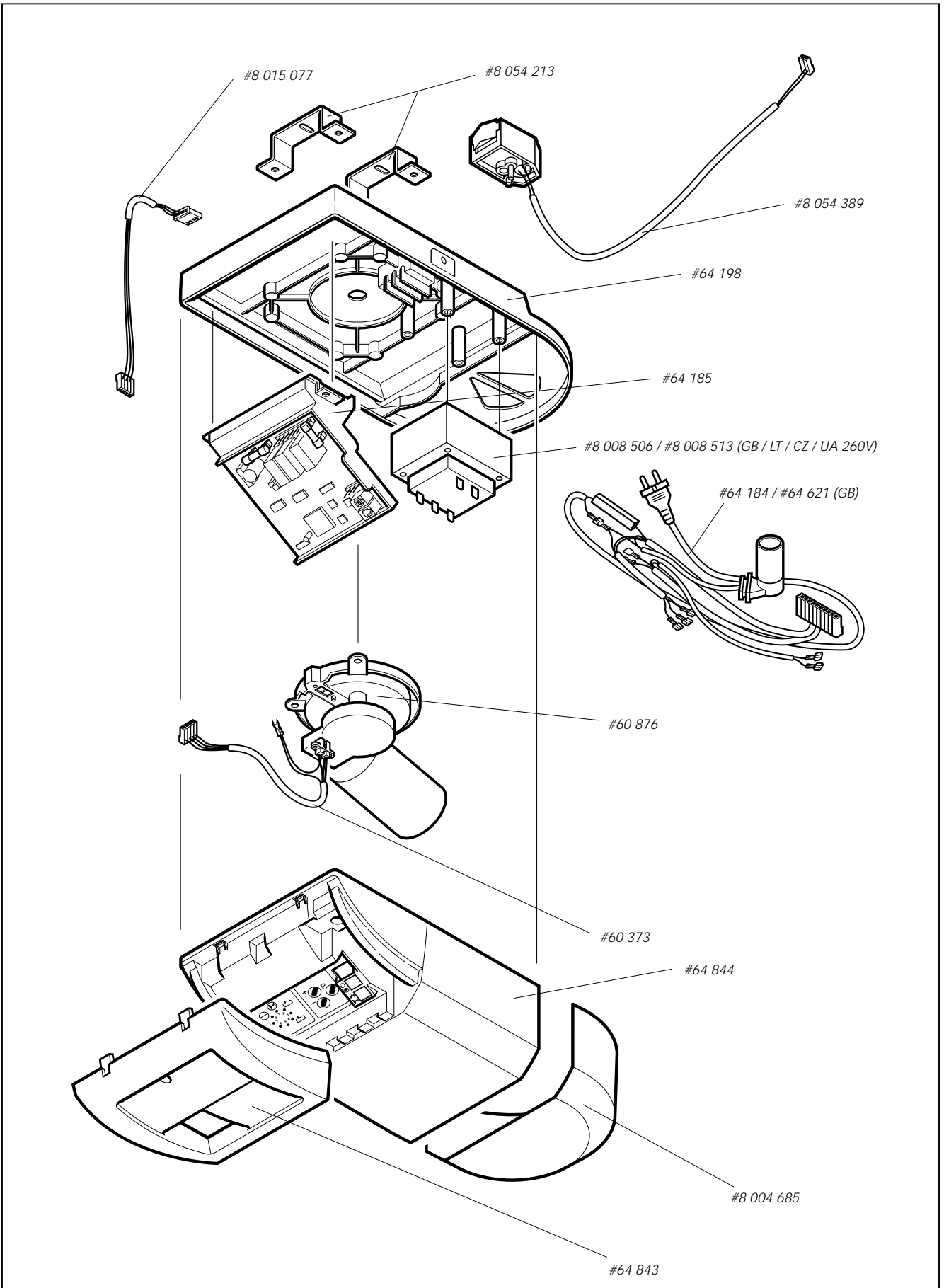

DEUTSCH	Urheberrechtlich geschützt. Nachdruck, auch auszugsweise, nur mit unserer Genehmigung. Änderungen, die dem technischen Fortschritt dienen, vorbehalten.	SVENSKA	Upphovsrättsskyddad. Eftertryck, även delvis, endast med vårt tillstånd. Med förbehåll för ändringar som tjänar den tekniska utvecklingen.
ENGLISH	Copyright. No part of this manual may be reproduced without our prior written approval. We reserve the right to alter details in the interests of progress.	NORSK	Beskyttet opphavsrett. Ettertrykk - også i utdrag - bare med vår tillatelse. Endringer, som tjener den tekniske utviklingen, forbeholdes.
FRANÇAIS	Copyright. Toute reproduction même partielle est interdite sans notre autorisation. Tous changements de constructions permis par l'évolution des techniques réservés.	MAGYAR	Szerzői jogvédelem alatt. Utánnnyomás, kivonatosan is, csak engedélyünkel. A műszaki fejlődést szolgáló módosítások jogát fenntartjuk magunknak.
NEDERLANDS	Door de auteurswet beschermd. Niets uit deze uitgave mag worden verveelvoudigd en/of openbaar gemaakt door middel van druk, fotocopie, microfilm of op welke andere wijze dan ook zonder voorafgaande toestemming van de uitgever. Technische wijzigingen voorbehouden.	SLOVENSKO	Vse avtorske pravice so zaščitene. Ponatis, tudi v izvlečkih, je možen samo z dovoljenjem. Spremembe ki so namenjene tehničnemu izboljšanju so tudi pridržane.
ITALIANO	Diritti d'autore riservati. Riproduzione, anche parziale, previa solo nostra autorizzazione. La Ditta si riserva la facoltà di apportare modifiche al prodotto in base al progresso tecnologico.	ČESKY	Chráněno autorským právem. Reprodukování, i ve výtazcích, jen s naším svolením. Změny sloužící technickému pokroku vyhrazeny.
ESPAÑOL	Copyright. Prohíbida la reproducción íntegra o parcial sin nuestra autorización. Reservado el derecho a modificaciones en el interés del perfeccionamiento técnico.	POLSKI	Prawa autorskie zastrzeżone. Kopiowanie, również fragmentów, tylko za zezwoleniem. Zastrzega się wprowadzanie zmian służących usprawnieniu technicznemu.
PORTUGUES	Reservados os direitos de autor. Reprodução, mesmo parcialmente, só com a nossa autorização. Sujeito a alterações que sirvam a evolução técnica.	LIETUVIŲ KALBA	Autorinės teisės saugomos. Kopijavimas, taip pat ir dalimis, tik su mūsų leidimu. Galimi technikos pažangos sąlygojami pakeitimai.
		РУССКИЙ	Авторские права защищены. Перепечатка, даже выборочная, только с нашего разрешения. Мы оставляем за собой право на внесение изменений, обусловленных техническим прогрессом.